

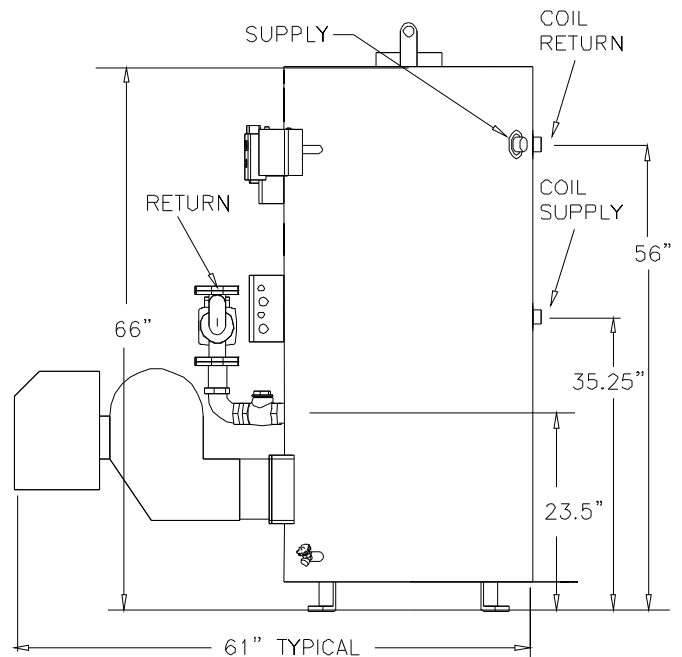

West Chicago, IL 60185
Phone: 630-562-2700
www.triadboiler.com

TRIAD BOILER SYSTEMS, INC. SERIES 900 SPACE HEAT and LOW TEMPERATURE BOILER

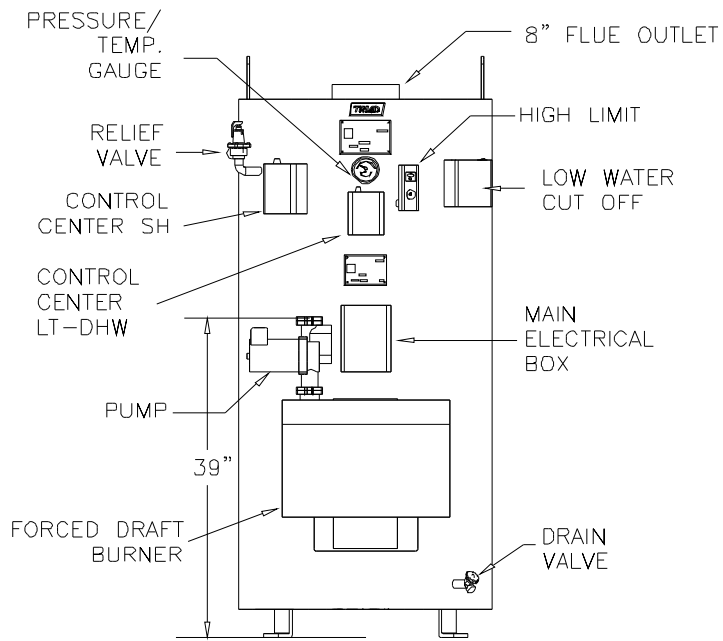
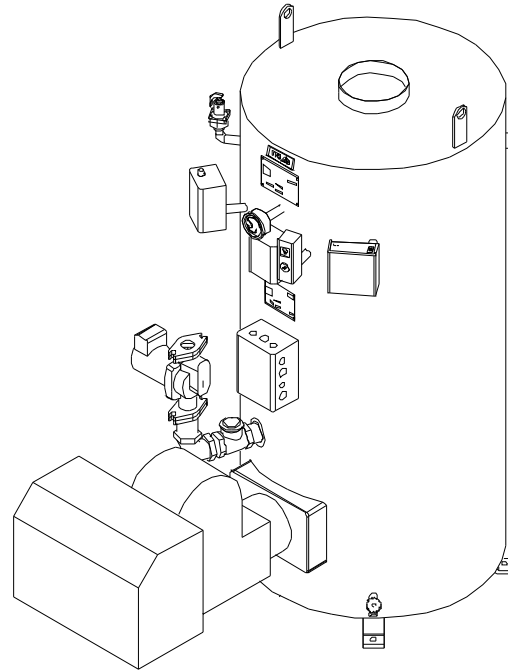
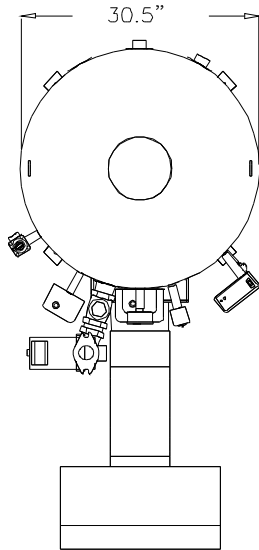

Note: Dimensions subject to change without notice.



TRIAD BOILER SYSTEMS, INC.
SERIES 900 BOILER (Model 900 SH-C-LT)

The Series 900 is a steel vertical firetube packaged boiler with a water-backed combustion chamber equipped with high-efficiency turbulators. Boilers come fully wired, and fit through a 32" doorway.

STANDARD EQUIPMENT:

- Forced Draft Burner (UL Listed)
- Circulating Pump – Vessel Water
- Circulating Pump – Coil Water
- Honeywell Control Centers for SH and LT
- Low Water Cut-Off
- Combination Pressure/Temperature Gauge
- Operating Light
- Relief Valve
- Second Safety High Limit with Manual Reset
- Vessel Pressure Rating of 125 PSI

OPTIONAL EQUIPMENT:

- Gas Fired (NG or Propane), Oil Fired, or Dual Fuel Burners
- UL, IRI, FM and CSD-1 Compliance
- Low-High, Low-High-Low and Modulating Gas Trains
- Sealed Combustion Air Intake
- Barometric Dampers
- LWCO with Manual or Auto Reset, Test Light, and/or Test Button
- UL Listed Boiler/Burner Package.

SPECIFICATIONS:

<i>Input BTU/Hr</i>	<i>Output BTU/Hr</i>	<i>Efficiency</i>	<i>GPM @ °F Rise Vessel Side</i>	<i>GPM @ °F Rise Coil Side</i>
600,000	508,800	84.8%	50.8 @ 20°F	20.3 @ 50°F
700,000	589,400	84.2%	58.9 @ 20°F	23.6 @ 50°F
800,000	664,800	83.1%	66.7 @ 20°F	26.7 @ 50°F
900,000	746,100	82.9%	59.6 @ 25°F	29.8 @ 50°F
1,000,000	822,000	82.2%	66.7 @ 25°F	33.0 @ 50°F

Note: Typical for Natural Gas. - Oil or LP burner data may vary.

APPLICATIONS:

- Space Heating and Process Water – typically 130°F - 210°F
- Low Temperature – typically 60°F - 130°F

CLEARANCES & CONNECTIONS:

- Clearance needed between boilers 6" (36" center to center) and 8" from front of burner for service.
- Vessel supply & return diameters – 2.0"; coil supply & return diameters – 1.5"

CONTROL:

The Series 900 can operate on its own controls, but a TRIAD microprocessor control panel is recommended for sequencing more than two boilers to minimize run-time and fuel usage.

FLUE: Category 1 when properly applied.

POWER: 120V, 60Hz, Single Phase, fused for 30 amps. Min / Max gas pressure, typically 5.6" / 14" WC

WEIGHT/VOLUME:

- Shipping Weight – 1,300 lbs.
- Operating Weight - 1,922 lbs.
- Vessel Water Volume – 75 Gallons

Factory built copper or steel mains available upon request.

TRIAD BOILER REPRESENTATIVE:

TRIAD Boiler Systems, Inc.

West Chicago, IL 60185
 Phone: 630-562-2700
 Fax: 630-562-2800
 Web: www.com.com