

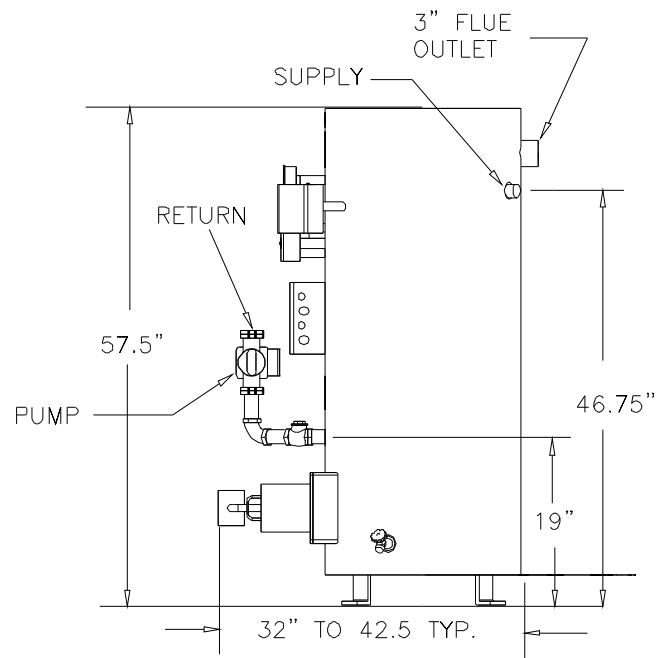

West Chicago, IL 60185
 Phone: 630-562-2700
www.triadboiler.com

TRIAD BOILER SYSTEMS, INC. SERIES 300 SPACE HEATING BOILER

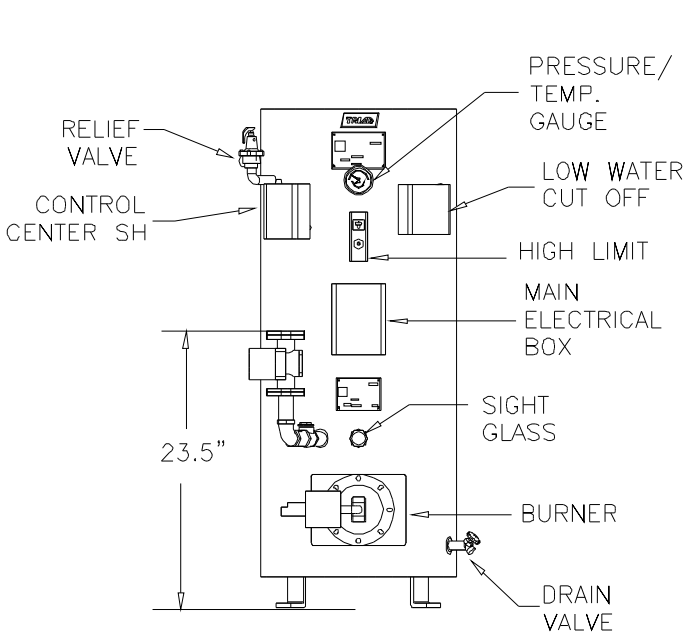
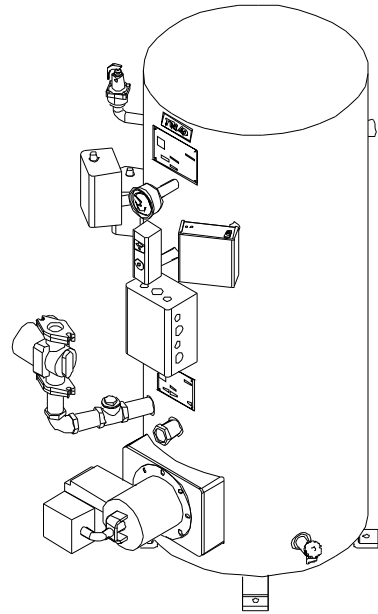
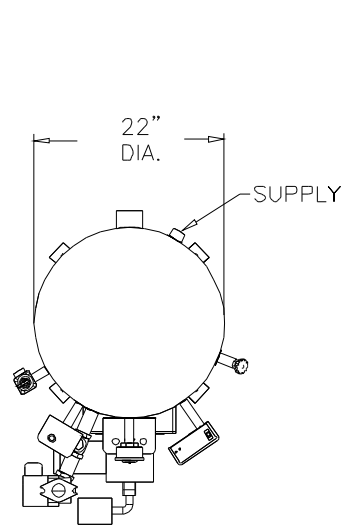

Note: Dimensions subject to change without notice.
 For ATM boiler, flue is 9" out the top, 6" if oil burner.



TRIAD BOILER SYSTEMS, INC.
SERIES 300 SPACE HEAT BOILER (Model 300 SH)

The Series 300 is a steel vertical firetube packaged boiler with a water-backed combustion chamber equipped with high-efficiency turbulators. Boilers come fully wired, and fit through a 24" doorway.

STANDARD EQUIPMENT:

- Forced Draft or Atmospheric Burner
- Circulating Pump
- Honeywell Control Center
- Low Water Cut-Off
- Combination Pressure/Temperature Gauge
- Operating Light
- Relief Valve
- Second Safety High Limit with Manual Reset
- Vessel Pressure Rating of 125 PSI

OPTIONAL EQUIPMENT:

- Gas Fired (NG or Propane), Oil Fired, or Dual Fuel
- UL and FM compliance.
- Sealed Combustion Air Intake for Forced Draft Burner
- Barometric Dampers
- LWCO with Manual or Auto Reset, Test Light, and/or Test Button

SPECIFICATIONS:

<i>Input BTU/Hr</i>	<i>Output BTU/Hr</i>	<i>Efficiency</i>	<i>GPM @ °F Rise</i>
210,000 ATM	171,990	82.0%	17.0 @ 20°F
300,000 ATM	240,400	80.1%	23.9 @ 20°F
210,000 HEP	182,280	86.8%	18.1 @ 20°F
300,000 HEP	255,000	85.0%	25.8 @ 20°F
399,000 HEP	332,300	84.3%	26.7 @ 25°F

Note: Typical for Natural Gas. - Oil or LP burner data may vary.

APPLICATIONS:

Space Heating and Process Water – typically 130°F - 210°F

CONNECTIONS:

- Supply Opening – 1.5"
- Return Opening – 1.25"

CONTROL:

The Series 300 can operate on its own controls, but a TRIAD microprocessor control panel is recommended for sequencing more than two boilers to minimize run-time and fuel usage.

POWER:

120V, 60Hz, Single Phase, fused for 10 amps (ATM burner) or 20 amps (Power burner).
 Min / Max gas pressure typically 5" / 14" WC.

WEIGHT/VOLUME:

- Shipping Weight – 750 lbs.
- Operating Weight - 1,040 lbs.
- Water Volume – 35 Gallons

Factory built copper or steel mains available upon request.

TRIAD BOILER REPRESENTATIVE:

TRIAD Boiler Systems, Inc.

West Chicago, IL 60185
 Phone: 630-562-2700
 Fax: 630-562-2800
 Web: www.com